

## Ultrahigh Symbol and Net-Bit Rate with IM/DD

### Description

A widely employed communication scheme is the intensity-modulation and direct detection (IM/DD), which is a low-complexity and low-cost solution. From the transmitter side, the intensity of an optical signal is transmitted through an optical fiber link. On the receiver side, the signal is detected by a photodiode (PD).

### Schematic Setup

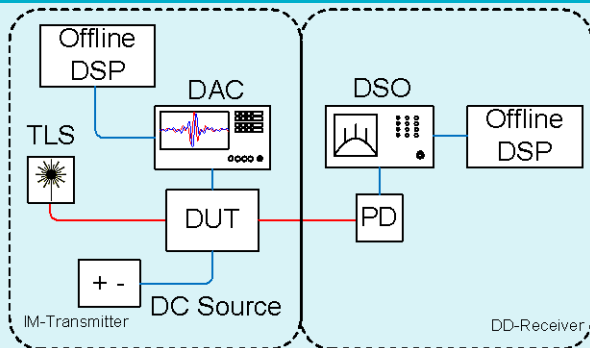

DAC:	Digital Analog Converter
DSO:	Digital Storage Oscilloscope
DSP:	Digital Signal Processing
DUT:	Device Under Test
PD:	Photodiode
TLS:	Tunable Laser Source

### Measurement

On the transmitter side, an electrical drive signal can be generated with offline DSP and a digital-to-analog converter (DAC). The signal is fed into a plasmonic MZM, which has a purely capacitive load. Therefore, twice the peak-to-peak voltage output from the DAC drops across the device. The electrical signal can be amplified with a driver before the modulator input. The optical signal comes from a laser source. For balanced MZMs, a DC source delivers a bias voltage to operate the modulator at its 3 dB working point. At the DD receiver a PD is connected to a digital storage oscilloscope (DSO) to record the signal. Depending on the receiver, the optical signal after the MZM can first be amplified by an erbium-doped fiber amplifier (EDFA) and filtered by

an optical band-pass filter (OBF). The recorded waveforms are then processed again with offline DSP. With the high BW plasmonic MZM (a), ultrahigh net bitrates and symbol rates can be achieved. Back-to-back 222 GBd OOK (b), 192 GBd PAM-2 (c), 152 GBd PAM-4 (d), and 140 GBd PAM-8 (e) can be shown.

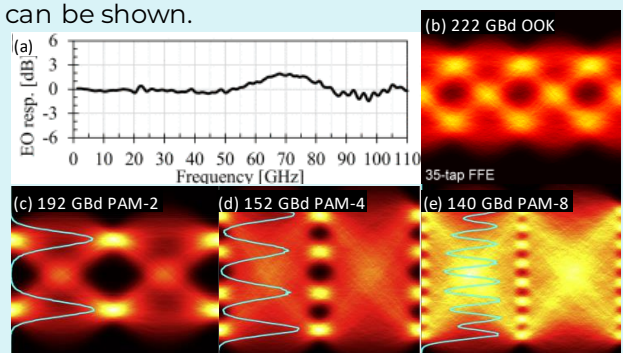

### References

- B. Baeuerle et al., "120 GBd plasmonic Mach-Zehnder modulator with a novel differential electrode design operated at a peak-to-peak drive voltage of 178 mV," *Opt. Express* 2019, doi: 10.1364/OE.27.016823
- Q. Hu et al., "Ultrahigh-Net-Bitrate 363 Gbit/s PAM-8 and 279 Gbit/s Polybinary Optical Transmission Using Plasmonic Mach-Zehnder Modulator," in *Journal of Lightwave Technology* 2022, doi: 10.1109/JLT.2022.3172246
- H. Mardoyan et al., "222-GBaud on-off keying transmitter using ultra-high-speed 2:1-selector and plasmonic modulator on silicon photonics," *ECOC 2019*, doi: 10.1049/cp.2019.1024